



# CWA-HPS1000A3/MT (S52)

# 1000W HPS Ballast 120/277/347V 60Hz

Application and Performance Specification

Input Volts	120	277	347
Circuit Type	CWA		
Power Factor	90% (min.)		
Regulation			
Line Volts	±10%		
Lamp Watts	±10%		
Line Current (A)			
Operating	9.63	3.97	3.15
Open Circuit	4.00	1.75	1.40
Starting	7.00	7.00	7.00
UL Temperature Ratings			
Insulation Class	H 180°C		
Temperature Code	B	B	A
Starting Temperature	-40°C (min.)		
Nominal Open Circuit Voltage	458	458	458
Input Watts	1100	1100	1100
Capacitor Specifications			
Microfarads	26µF		
Volts	540V (min.)		
60Hz Test Procedures			
High Potential Test (Volts)			
1 minute	2000	2000	2000
2 seconds	2300	2300	2300
Secondary Open Circuit Voltage (V)	410-470	410-470	410-470
Secondary Short-Circuit Current (A)	6.30-7.80	6.30-7.80	6.30-7.80
Input Open Circuit Current (A)	2.90-4.50	1.30-2.50	0.60-1.70
Input Short-Circuit Current (A)	5.70-8.70	2.50-4.10	1.10-2.90
Core & Coil Specification			
Dimensions A	110 mm		
Dimensions B	165 mm		
Weight	11.80 kg		

Wiring Diagram

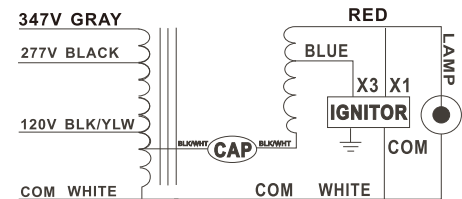

Core and Coil Dimensions

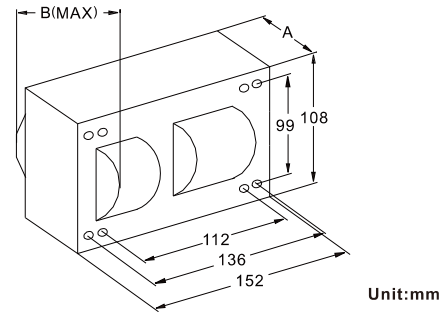

Capacitor and Ignitor Dimensions

Capacitor: 26UF/540V Ignitor: HPS1000WA

Rated Temp: 105°C  
Height: 110mm  
Width/Diameter: 53mm

Rated: 105°C  
BLT: 25ft

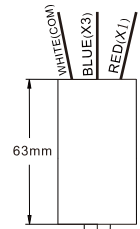
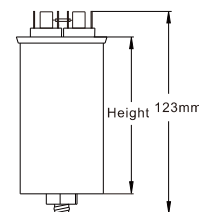
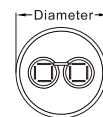

© All documentation is subject to change without notice. Please refer to our website for the latest product information and specifications. Please contact us for details.

[www.lumenefficientdesign.ca](http://www.lumenefficientdesign.ca)