

(TF) LED TROFFER CCT/OUTPUT SELECTABLE DLC 5.1 Standard Version

Features

- Modern centre basket design for excellent lighting distribution and colour consistency
- New lightweight and ultra slim design
- Fits standard ceiling T-Bar/Grid dimensions
- Available in 2x2 and 2x4 dimensions
- CCT Selectable: 3500K, 4000K, 5000K
- 2x2 Output Selectable: 25W, 30W, 40W
- 2x4 Output Selectable: 30W, 40W, 50W
- 110lm/W luminous efficacy
- Features a durable, UV-resistant PC lens
- Unified Glare Rating (UGR) <22
- Seamless aluminum frame featuring double-sided welding technology and SPCC back plate ensures a strong structure and improved heat dissipation
- Oversized integrated junction box for quick and easy installation
- Features premium SMD 2835 LED chips
- L70 rated chip for >50,000hours projected life
- Input voltage 120-347Vac
- 0-10V dimmable driver
- Flicker-free driver as standard
- Damp location rated
- Colour Rendering Index (CRI) 80
- Power factor >0.95
- Voltage frequency 50/60Hz
- Operating temperature -25°C to 40°C
- 5-year warranty



Specifications

Part Number	LED-TF22-347V-40D	LED-TF24-347V-50D
Wattage Selectable	25W-30W-40W	30W-40W-50W
LED Type	SMD 2835	
Luminous Efficacy (4000K, Ra80)	110lm/W (±5%)	
CCT Selectable	3500K, 4000K, 5000K	
CRI	Ra80	
Beam Angle	110°	
Unified Glare Rating (UGR)	<22	
LED Driver	Flicker-Free	
Input Voltage	120-347Vac @50-60Hz	
Power Factor	>0.95	
Surge Protection	2.5kV	
Driver Type	Constant Current (CC)	
Material (Housing)	Aluminum Frame + SPCC Back Plate	
Material (Lens)	PC	
Housing Finish	Polyester Powder Coating	
Housing Colour	White	
IP Rating	IP20 (DAMP)	
Operating Temperature	-25°C to +40°C (-13°F to +122°F)	
Projected life (L70)	>50,000 hours (Ta=25°C@L70)	
Warranty	5 years	
Dimming Function	0-10V dimming	
Mounting Options	Recessed	
Certificates	cULus, DLC 5.1	



Specifications

Photometrics

LUMINOUS INTENSITY DISTRIBUTION

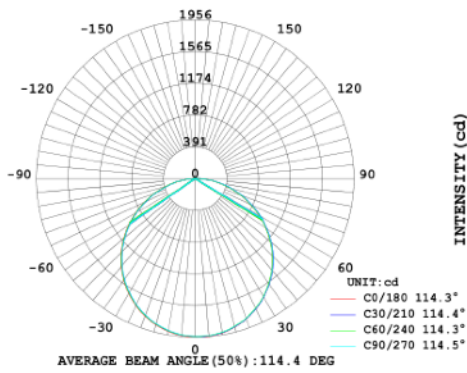

Dimensions for LED-TF22-347V-40D

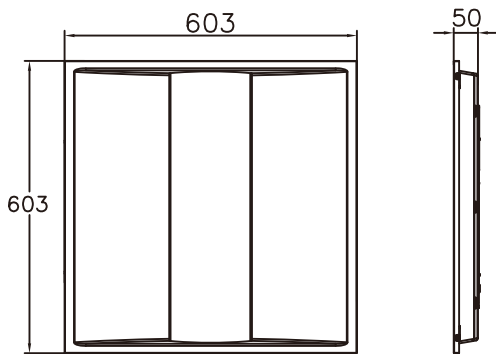

Part Number

LED-TF22-347V-40D

Quantity Per Package

2pcs

Net Weight

5.20±0.3kg (11.46±0.66Lbs)

Gross Weight

7.20±0.3kg (15.87±0.66Lbs)

Export Package Dimensions

635mm x 120mm x 635mm (25.00" x 4.72" x 25.00")

Specifications

Dimensions for LED-TF24-347V-50D

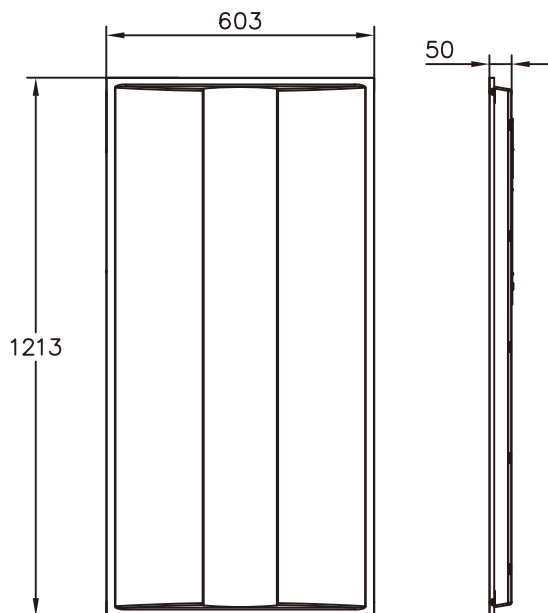

Part Number

LED-TF24-347V-50D

Quantity Per Master Package

2pcs

Net Weight

7.00±0.3kg (15.43±0.66Lbs)

Gross Weight

12.30±0.3kg (27.12±0.66Lbs)

Export Package Dimensions

1245mm x 120mm x 635mm (49.02" x 4.72" x 25.00")



Integrated
Junction Box

Lumen Efficient Design Inc. lumenefficientdesign.ca

All documentation is subject to change without notice. Please contact us for details.
email. dgreenlaw@lumenefficientdesign.com sales. 647.450.0868 tel. 705.207.6793